

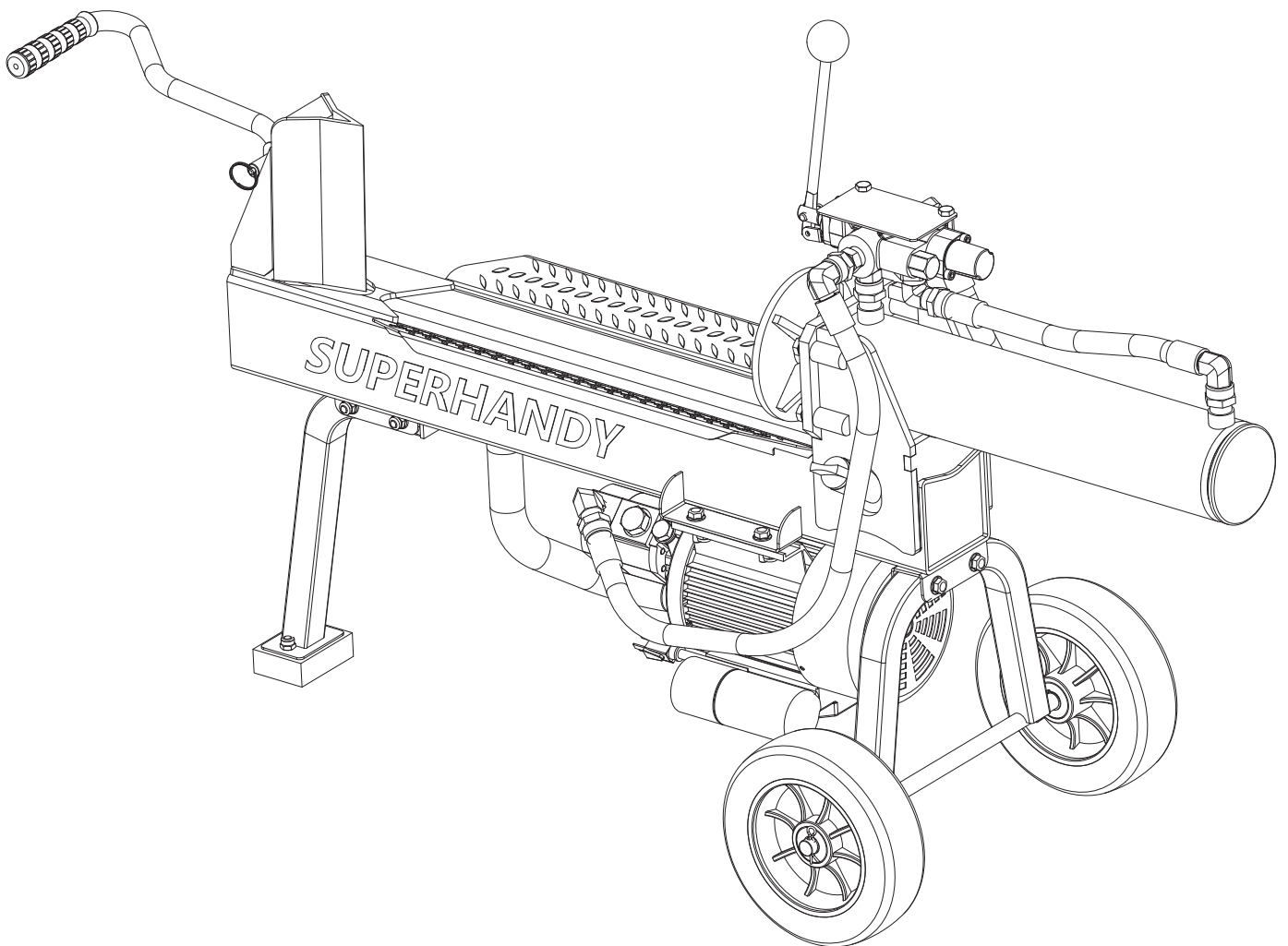

# Electric Powered Hydraulic Log Splitter Operator's Manual

---



---

**WARNING:**

Read carefully and understand all **INSTRUCTIONS** before operating. Failure to follow the safety rules and other basic safety precautions may result in serious personal injury. Save these instructions in a safe place and on hand so that they can be read when required. Keep these instructions to assist in future servicing.

---

# INDEX

TECHNICAL SPECIFICATIONS .....	1
SAFETY DEFINITIONS .....	2
SAFETY SYMBOLS .....	2
SAFETY GUIDELINES .....	4
ELECTRICAL SAFETY .....	5
CONTROLS AND FEATURES .....	5
PARTS LIST .....	6
EXPANDED DRAWINGS .....	9
MAINTENANCE AND STORAGE .....	11
TROUBLE SHOOTING .....	11

## TECHNICAL SPECIFICATIONS





Maximum Exerted Splitting Force	14 (US tons)
Electromotor Specifications	120V, 60Hz, 15A, 1700RPM
Starter Type	Electric Start
Cycle Time	16.5sec.
Gear Pump	10GPM / 38LPM
Control Valve	Detent (auto-return)
Hydraulic Cylinder Stroke Length	16"
Max Log Length	20.5"
Max Log Diameter	16"
Hydraulic Fluid Type	AW32, AW46
Hydraulic Fluid Tank Capacity	2.1Gal. (8L)
Wheel Diameter	8"
Wire length	70.9"
Net Weight	126LB
Overall Dimensions(L x W x H)	47.09" x 14.02" x 33.98" (Assembled)







# SAFETY DEFINITIONS

The purpose of safety symbols is to attract your attention to possible dangers. The safety symbols, and their explanations, deserve your careful attention and review. The safety warnings do not by themselves eliminate any danger. The instructions or warnings they give are not substitutes for proper accident prevention measures and care while using the product.

# SAFETY SYMBOLS

Some of the following symbols are used on this product. Please study them and learn their meanings. Proper interpretation of these symbols will help you to operate the product in a safe and responsible manner.

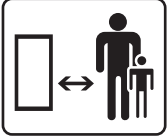
SYMBOL	MEANING
	<p><b>Read Operator’s Manual in its entirety.</b> To reduce the risk of injury, user must read and understand operator’s manual before using this product.</p>
	<p><b>Eye and Ear Protection.</b> Always wear safety goggles or safety glasses with side shields, and as necessary a full face-shield as well as full ear protection when operating this product.</p>
	<p><b>Footwear.</b> Always wear safety shoes or work boots when operating the machine. Sandals and slippers or open toe shoes or any type are strongly discouraged.</p>
	<p><b>Gloves.</b> Always wear nonslip, heavy-duty protective gloves when operating this product.</p>
	<p><b>Safety Alert.</b> Precautions that involve your safety.</p>
	<p><b>Risk of Fire.</b> Do not touch the log splitter by wet hands or wet cloth to avoid the electrical short circuit and fire. Do not cover the motor to avoid excessive temperature and cause fire.</p>
	<p><b>Skin Injection Hazard.</b> Hydraulic oil under high pressure can penetrate your clothes skin. Make sure all fittings are fully seated and tightly secured before applying pressure. Relieve system pressure before servicing.</p>
	<p>Always keep hands away from the wedge and the ram. Moving parts can crush or cut.</p>

SYMBOL	MANING
	<p>Always keep feet away from the wedge and the ram. Moving parts can crush or cut.</p>
	<p><b>Hot Surface.</b> To reduce the risk of injury or damage, avoid contact with any hot surface.</p>
	<p><b>Open Flame alert.</b> The power cord is extremely flammable. Keep the splitter away from open flames, sparks, pilot lights, heat, and other potential ignition sources.</p>
	<p><b>Hold logs on sides when loading.</b> Keep hands and feet away from cylinder, wedge, and partially split logs.</p>
	<p>Never place hands or any part of the body between a log and any part of the log splitter. Do not split logs against the grain. Split logs end to end in the direction of the grain only.</p>
	<p><b>Clearance.</b> Keep all objects including others at least 10 feet (3m) from this machine. Only one person should operate the log splitter and load the logs.</p>
	<p><b>Never operate on an incline.</b> Make sure the splitter is on a level surface. Block tires and ensure support leg is secure to prevent unintended movement of the log splitter during operation.</p>

## **⚠ DANGER**

DANGER indicates a hazardous situation which, if not avoided, will result in serious injury and possibly death.

## **⚠ WARNING**

WARNING indicates a potential hazardous situation which, if not avoided, could result in serious injury or death.

## **⚠ CAUTION**

CAUTION indicates a hazardous situation which, if not avoided, could result in minor or moderate injury.

## **⚠ NOTE**

NOTICE indicates information considered important, but not hazard-related (e.g., messages relating to property damaged).

## **SAFETY GUIDELINES**

### **⚠ WARNING**

Cancer and Reproductive Harm – [www.P65Warnings.ca.gov](http://www.P65Warnings.ca.gov)

### **⚠ DANGER**

Moving parts can entangle hands, feet, hair, clothing and/or accessories. Traumatic amputation or severe laceration can result. Keep hands and feet clear moving parts. Tie up long hair and remove jewelry before operating the device. Operate equipment only fully assembled and with guards in place.

**DO NOT** wear loose-fitting clothing, dangling drawstrings or items that could become caught.

### **⚠ WARNING**

Operation of this equipment may create sparks that can start fires around dry vegetation.

Spark arrestor may be required. The operator should contact local fire agencies for laws or regulations relating to fire prevention requirements.

### **⚠ WARNING**

Crush Hazard

Wedge can cut through skin and break bones and in extreme cases amputate limbs and digits. Keep all limbs away from wedge and endplate at all times.

### **⚠ WARNING**

Skin Injection Hazard. High pressure hydraulic oil can break skin and cause severe injury.

Make sure all fittings are seated firmly and tightly secured before applying pressure. Relieve system of pressure before servicing.

### **⚠ CAUTION**

Parts of the hydraulic circuit (cylinder, pump, valve-body, hoses) can become very hot during operation.

### **⚠ WARNING**

This product IS NOT intended to be towed behind a vehicle of any sort. The handle and wheels of the product are intended for the sole purpose of easily moving the log splitter on your work site. Any modification or changes to allow moving of this product by any other means other than by hand will render all warranties null and void.

### **⚠ CAUTION**

Improper treatment or use of the log splitter can damage it, shorten its life and void your warranty. Use the log splitter only for intended uses.

Operate only on level surfaces.

**DO NOT** expose log splitter to excessive moisture, dust, or dirt. Cover with a tarp or store in a shed when not in use.

**DO NOT** allow any material to block the cooling vents.

**DO NOT** use product if you observe electromotor if:

- Equipment sparks, smokes or flames from the motor
- Equipment vibrates excessively.
- Hydraulic Fluid is leaking from the unit

## ELECTRICAL SAFETY

### **⚠ DANGER**

Power tool plugs must match the outlet. Never modify the plug in any way.

**DO NOT** use any adapter plugs with earthed (grounded) power tools. Unmodified plugs and matching outlets will reduce risk of electric shock.

### **⚠ WARNING**

Avoid body contact with earthed or grounded surfaces such as pipes, radiators, ranges and refrigerators. There is an increased risk of electric shock if your body is earthed or grounded.

### **⚠ DANGER**

**DO NOT** expose power tools to rain or wet conditions. Water entering a power tool will increase the risk of electric shock.

### **⚠ DANGER**

**DO NOT** abuse the cord. Never use the cord for carrying, pulling or unplugging the power tool. Keep cord away from heat, oil, sharp edges or moving parts. Damaged or entangled cords increase the risk of electric shock.

### **⚠ CAUTION**

When operating a power tool outdoors, use an extension cord suitable for outdoor use. Use of a cord suitable for outdoor use reduces the risk of electric shock.

### **⚠ CAUTION**

If operating a power tool in a damp location is unavoidable, use a ground fault circuit interrupter (GFCI) protected supply. Use of a GFCI reduces the risk of electric shock.

## CONTROLS AND FEATURES

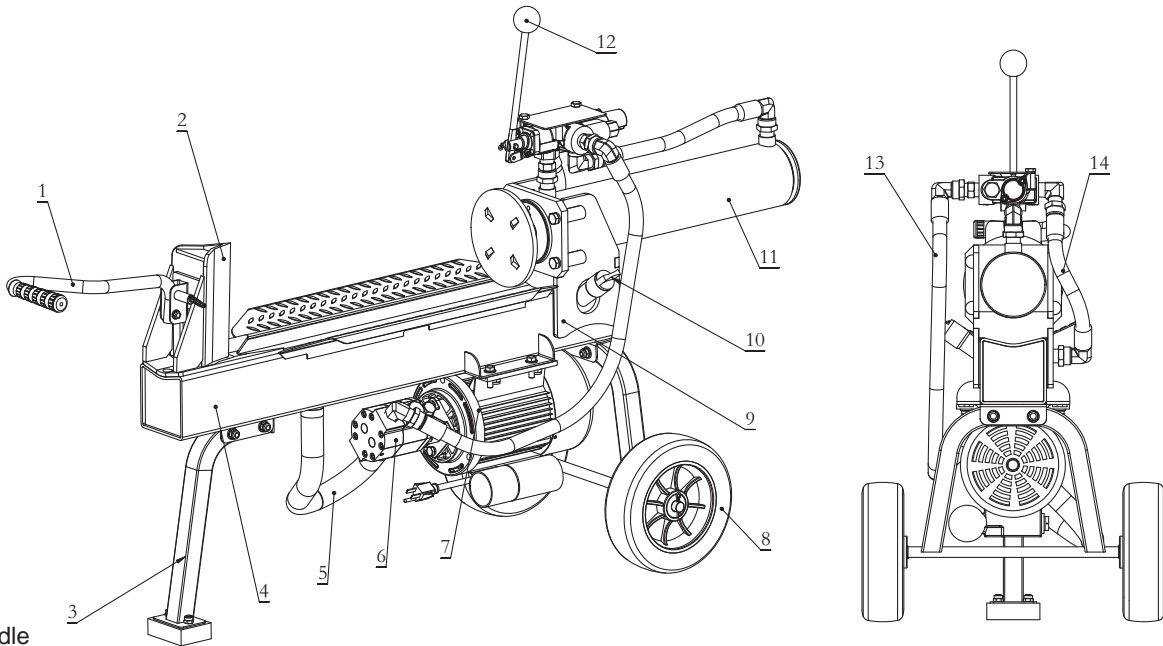

1. Handle
2. Splitting Wedge
3. Support Leg – Supports log splitter while operating.
4. Splitting Support Beam---DO NOT PUNCTURE The hydraulic tank is inside.
5. Suction Hose – Draws hydraulic oil from the tank into the pump.
6. Hydraulic Pump – Pumps hydraulic oil through the system.
7. Electromotor – 120V.
8. 8" Wheels
9. Hydraulic cylinder base.
10. Hydraulic Oil Dipstick – Add or check Hydraulic oil level.
11. Hydraulic Cylinder – Converts hydraulic pressure into linear force.
12. Control Valve Handle – Controls the movement of the thrust plate.
13. Hydraulic Oil Inlet (High Pressure) Hose – Feeds hydraulic oil into the hydraulic cylinder.
14. Hydraulic Oil Return (Low Pressure) Hose – returns hydraulic oil back into the hydraulic tank.

# PARTS LIST

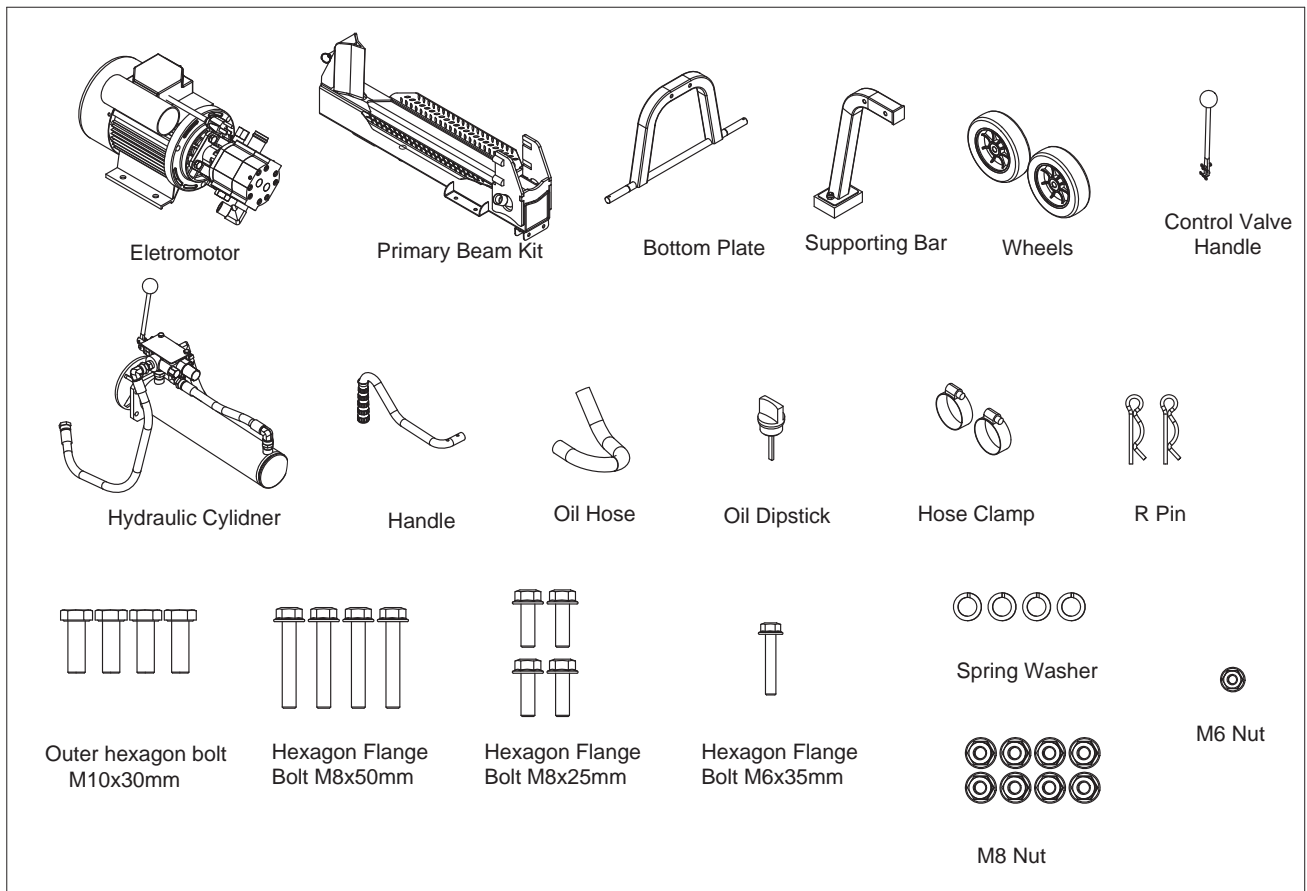

# ASSEMBLY

Recommended tools



STEP #1

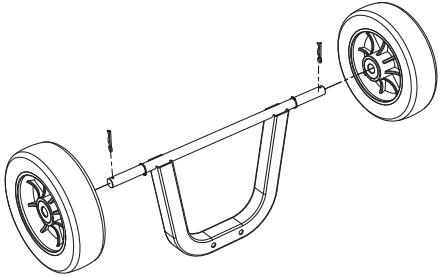

Recommended tools: Needle nose pliers

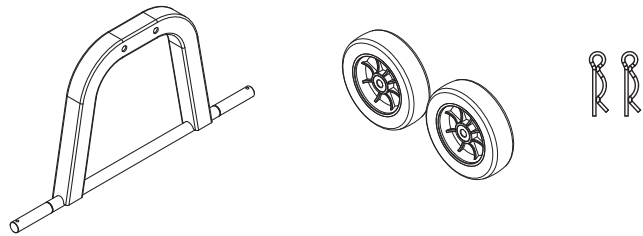

STEP #2

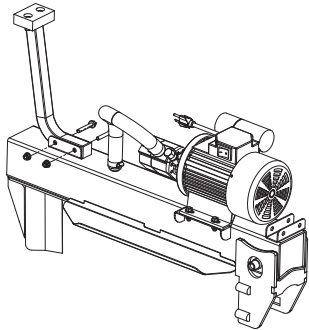

Recommended tools: Ratchet Wrench (13mm)

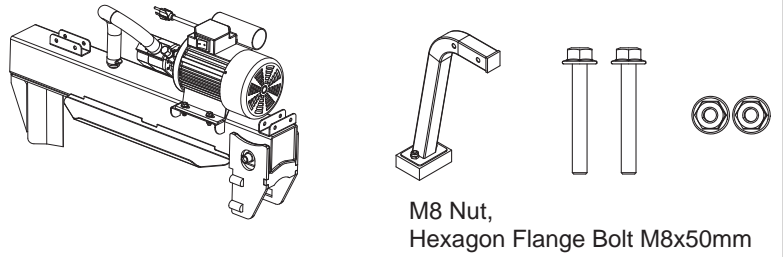

STEP #3

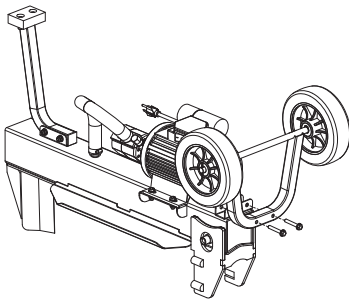

Recommended tools: Ratchet Wrench (13mm)

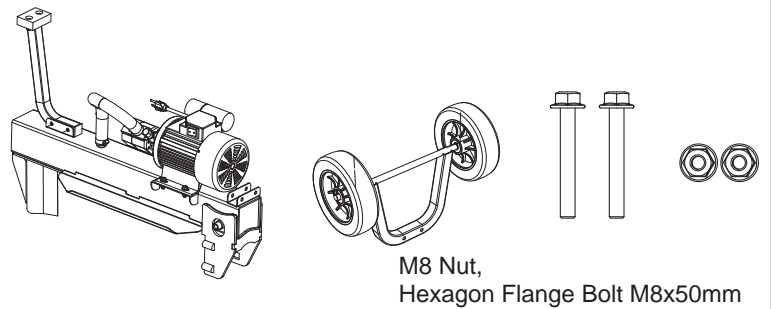

STEP #4

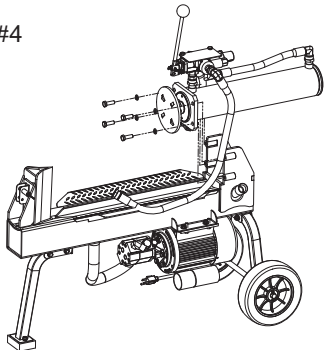

Recommended tools: Ratchet Wrench (16mm)

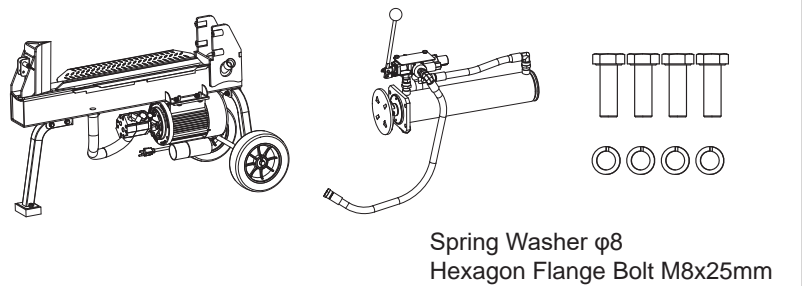



STEP #5

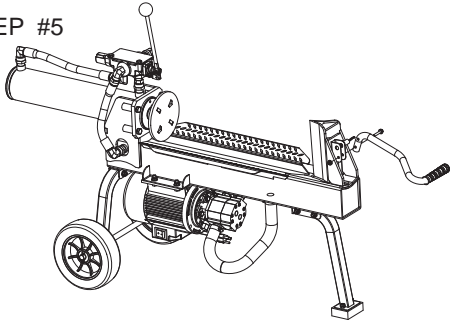

Recommended tools: Ratched wrench (10mm)

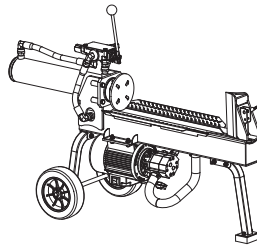

M6 Nut,  
Hexagon Flange Bolt M6x35mm,

STEP #6

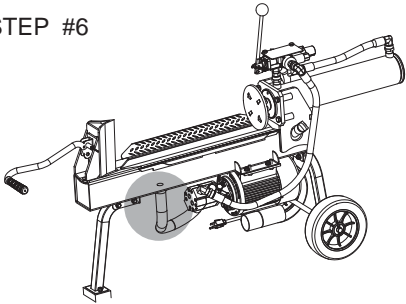

Recommended tools: Slotted screwdriver

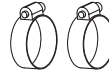
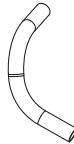

STEP #7

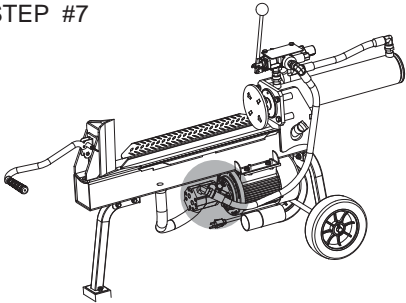

Recommended tools: Wrench (27mm 22mm)

STEP #8

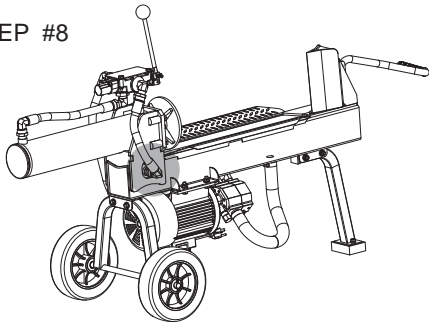

Recommended tools: Wrench (27mm 22mm)

STEP #9

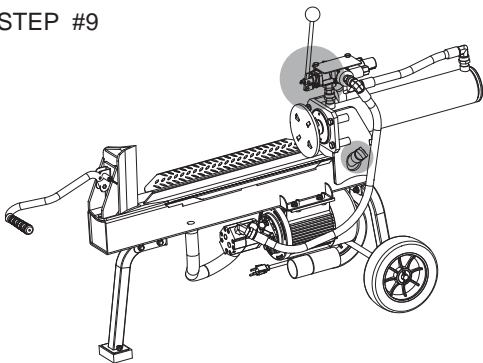

STEP #10

**Add hydraulic fluid before first Use.**

# EXPLODED DRAWINGS

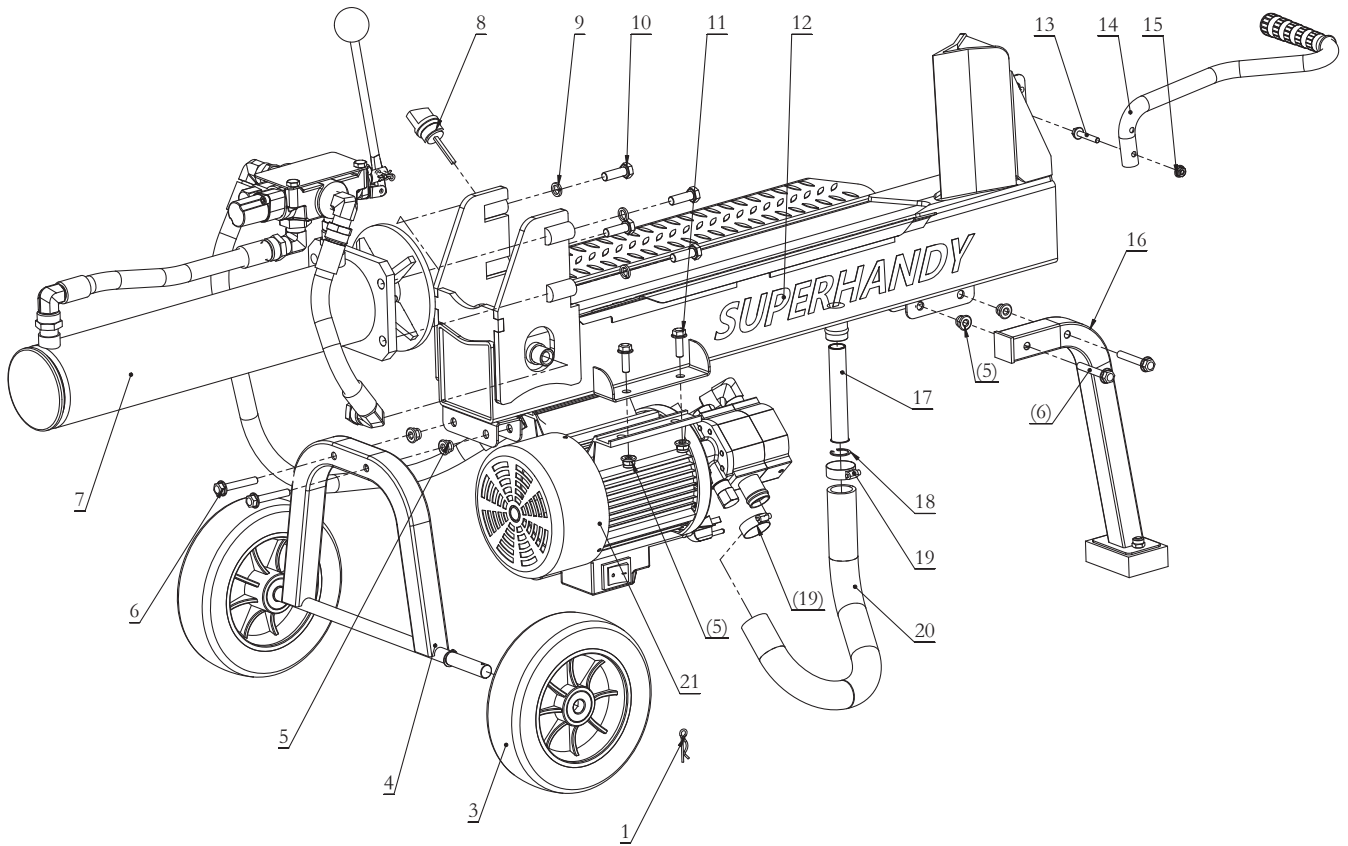

Part No.	Description	Q'ty	Part No.	Description	Q'ty
1	R Pin	2	12	Primary Beam Kit	1
3	8 " Wheel	2	13	Hexagon Flange Bolt M6x35mm	1
4	Bottom Plate	1	14	Handle	1
5	Flange Nut M8	8	15	Flange Nut M6	1
6	Hexagon Flange Bolt M8x50mm	4	16	Supporting Bar	1
7	Hydraulic Cylinder Kit	1	17	Filter	1
8	Oil Dipstick	1	18	Elastic Ring	1
9	Spring Washer	4	19	Hose Clamp	2
10	Outer hexagon bolt M10x 30mm	4	20	Oil Hose	1
11	Hexagon Flange Bolt M8x25mm	4	21	Electromotor	1

## OPERATION

1. Read the Operator's Manual completely before attempting to use this log splitter.
2. Do not allow anyone to operate your log splitter who has not read the Operator's Manual or has not been instructed on the safe use of the log splitter.
3. Never allow children or untrained adults to operate this machine.
4. Never leave the machine unattended with the electromotor running.
5. Never operate the machine when under the influence of alcohol, drugs or medication
6. Many accidents occur when more than one (1) person operates the log splitter. If a helper is assisting in loading logs to be split, never actuate controls until helper is clear of the area.
7. Never allow anyone to ride on the machine during use or during operation.
8. Never transport cargo on the log splitter.
9. Always operate the log splitter with all safety equipment in place and all controls properly adjusted for safe operation.
10. High fluid pressures are contained in hydraulic log splitters.  
Pressurized hydraulic fluid escaping through a pin hole opening can puncture skin and cause sever bleeding and result in blood poisoning. Therefore, the following instructions should be heeded at all times.
  - Be sure to confirm all hose connections and hose clamps are tight before each use. It is possible for connections to vibrate loose over time
  - Do not operate the unit with frayed, kinked, cracked or damaged hoses, fittings, or tubing.
  - Stop the electromotor and relieve hydraulic system pressure before changing or adjusting fittings, hoses, tubing, or other system components.
  - Do not adjust the pressure settings of the pump or valve. The factory presets are tested for optimal system performance. Tampering with or modifying these settings will render your product warranty nu,, and void.
  - Do not check for leaks with your hand. Leaks can be detected by passing cardboard or wood over the suspected area. Look for discoloration. If injured by escaping fluid, see a doctor at once. Serious infection or allergic reaction can develop if proper medical treatment is not administered immediately.
11. Keep the operation zone and adjacent area clear for safe, secure footing.
12. Always keep hands and feet clear of moving parts.
13. Log splitters should be used only for splitting wood. Do not use for other purposes unless the manufacturer provides attachments and instructions for such purposes.
14. When loading a ram-type log splitter, place your hands on the sides of the log, not the ends. Never place your hands or any part of your body between a log and any part of the log splitter
15. Only split wood WITH the grain. NEVER split perpendicular to the grain.
16. On ram-type log splitters, never attempt to split more than one log at a time unless the ram has been fully retracted and a second log is needed to complete the splitting of the first log.
17. On ram-type log splitters when the logs are not squared, the longest portion of the log should be rotated down and the most squared end placed against the ram.
18. Use only your hand to operate the log splitter controls, never kick the handle with your feet.

### Add Hydraulic Oil

**DO NOT** remove the hydraulic oil fill cap when the electromotor is running or hot. Hot oil can escape causing severe burns. Always allow the log splitter to cool completely before removing the hydraulic oil cap.

High fluid pressure and temperatures are created in the hydraulic log splitters. Hydraulic fluid will escape through a pin-size hole opening and can puncture skin.

Inspect hydraulic system regularly for possible leaks.

Never check for leaks with your hand while the system is pressurized. Seek medical attention immediately if injured by escaping fluid.

### **NOTE**

To check hydraulic oil level, insert the dipstick into fill neck until it stops. Remove and read level. Do not thread dipstick into fill neck when checking oil.

When the outdoor temperature is below 32°F , Dexron III transmission fluid can be used.

1. Make sure the log splitter is on a flat, level surface.
2. Remove the dipstick from the oil tank.
3. Add 1.6gallon of hydraulic oil - AW32 / AW46
4. Check hydraulic oil level with oil dipstick. The oil level should be on the dipstick.
5. Tighten the dipstick.
6. Start electromotor.
7. Extend and retract the cylinder to purge air from the hydraulic system. Cylinder motion should be smooth and continuous.
8. Shut-off electromotor.
9. Hydraulic oil can be added appropriately when the cylinder thrust is insufficient.

### **WARNING**

**For safety reasons, hydraulic oil is not included in the package.**

## MAINTENANCE AND STORAGE

1. Always shut off the power source while repairing or adjusting the splitter except as recommended by the manufacturer.
2. Clear debris from movable parts, but only when the power source is shut off.
3. Check to be sure all nuts and bolts are tight to assure the equipment is in safe working condition prior to each usage, and periodically during usage. Electromotor vibration may shake screws and bolts loose during operation.

## TROUBLE SHOOTING

Problem	Cause	Solution
Electromotor will not start.	No electricity.	Waiting for electricity.
	No plug in.	Plug in.
	Power switch is OFF.	Turn on the power switch.
Electromotor starts but runs loudly.	Something in the motor.	Remove impurity.
	Motor cover interferes with vane.	Adjusting motor cover.
	Air in the hydraulic oil system.	Purge air by extending and retracting the wedge several times until motion is smooth.
	Debris lodged in beam guides.	Clear the filter net from beam.
	Low hydraulic oil.	Check oil level and add as needed.
Wedge movement is slow or erratic.	Faulty cylinder rod seal.	Contact Customer Service.
	Scored or bent cylinder rod.	Contact Customer Service.
	Loose hydraulic fitting.	Tighten hydraulic fitting.
	Hydraulic oil is not continuous.	Add hydraulic fluid. Clear the filter net from beam.
Oil leak from cylinder.	Faulty combination washer seal on cylinder hydraulic fitting.	Contact Customer Service.
Wedge will not extend or retract.	Faulty control valve.	Contact Customer Service.
	Faulty hydraulic pump.	Check oil level and add as needed.
	Low hydraulic oil.	Inflate tires to proper pressure. Refer to tire
The hose is twisted after tightening.	The hose rotates.	Clamp the hose sleeve with pipe pliers and tighten the joint with a wrench.
The valve stem springs back multiple times.	There is air in the hydraulic hoses.	Unscrew oil dipstick to vent.



Great Circle USA  
 Support Line: 1-866-493-0524  
[help@greatcircleus.com](mailto:help@greatcircleus.com)  
[www.greatcircleus.com](http://www.greatcircleus.com)